

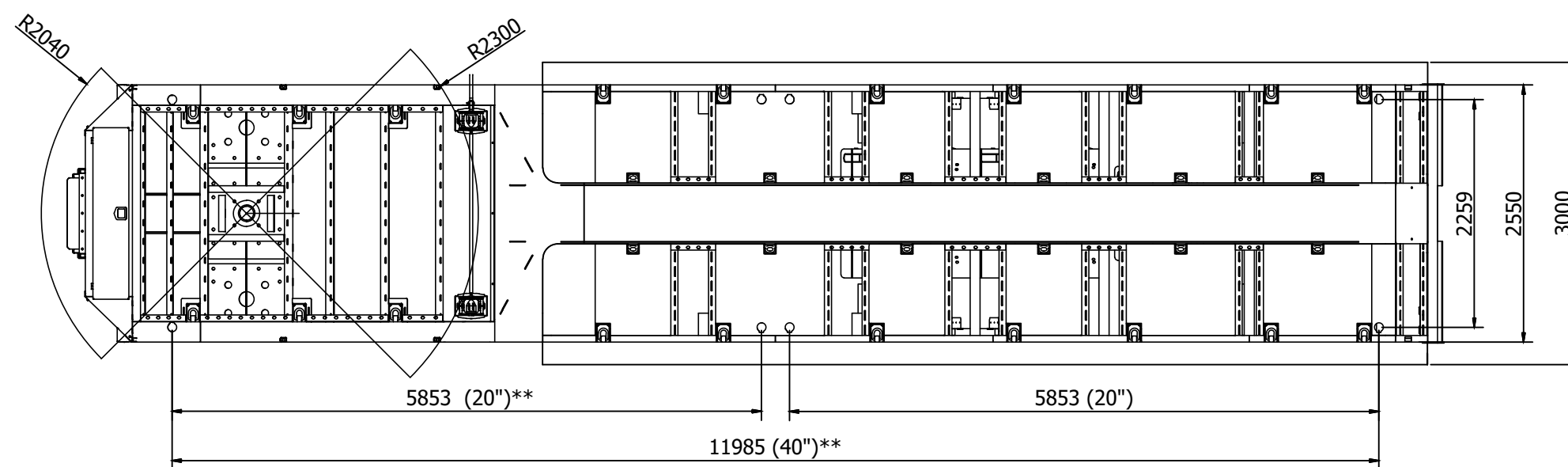

3.NNP-S-1N

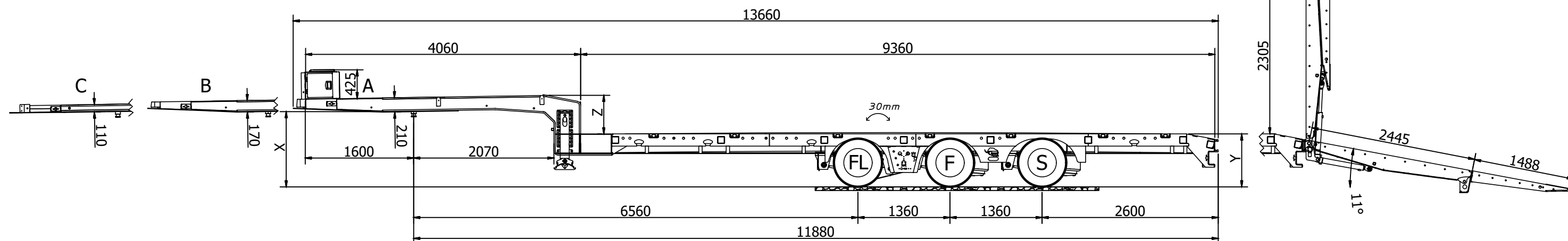

ROZMIAR OPONY / TIRE SIZE	WYSOKOŚĆ POKŁADU / LOADING DECK HEIGHT	SZYJA : / NECK :	X = 950	X = 1050	X = 1150	X = 1250	X = 1350	X = 1450
			Z =	Z =	Z =	Z =	Z =	Z =
205/65 R17,5"	Y = 800*	A	360	460	560	660	760	860
		B	320	420	520	620	720	820
		C	260	360	460	560	660	760
235/75 R17,5" 245/70 R17,5"	Y = 900*	A	260	360	460	560	660	760
		B	220	320	420	520	620	720
		C	160	260	360	460	560	660

- (F) OŚ STAŁA / FIXED AXLE
 - (S) OŚ SKRĘTNA / SELF-STEERING AXLE
 - (FL) OŚ PODNOSZONA / LIFT AXLE
 - (SL) OŚ SKRĘTNA PODNOSZONA / SELF-STEERING LIFT AXLE
 - (H) OŚ HYDRAULICZNA / HYDRAULIC AXLE
- **WYMAGANY STÓŁ WSPORCZY /
**LEVERING BRIDGE REQUIRED

* +/- 20mm W ZALEŻNOŚCI OD OBCIĄŻENIA ŁADUNKIEM NACZEPY /
* +/- 20mm DEPENDING ON THE LOAD ON THE SEMI-TRAILER